

## 1. Introduction

Fiber optic sensors are made up of two main parts: the fiber optic transducer (also called the fiber optic gauge or the fiber optic probe) and the signal conditioner (also called the readout or the interrogation unit). The fiber optic transducer is made of a proof body which contains an optical device that is sensitive to the physical magnitude to be measured, i.e. the measurand. For non-distributed sensors, the sensitive part of the transducer is usually mounted at the tip of an optical fiber that connects to the signal conditioner unit. The later is used for injecting light into the optical fiber, receiving the modified light signal returned by the transducer as well as for processing the modified light signal and converting the results into physical units of the measurand.

There are different methods for fiber optic sensing which are based on the specific properties of the light radiation (intensity, phase, polarization, and spectrum) to be modulated by the measurand. Among them, optical interferometry, which concerns the phase modulation of the light radiation, is recognized as the most sensitive method for fiber optic sensing. Indeed, the interferometer is known as a very accurate optical measurement tool for measuring a physical quantity by means of the measurand-induced changes of the interferometer path length difference. However, when using a narrowband light source (such as a laser source), the coherence length of the source is generally greater than the path length difference of the interferometer and therefore the measurement suffers from a  $2\pi$  phase ambiguity, due to the periodic nature of the interferogram fringes. This problem may severely restrict the measuring applications and this is why it has prohibited many interferometric fiber optic sensors to meet acceptance within the measurement industry. The phase ambiguity problem is avoided by using a light source with short coherence length that is a light source with a broadband

spectrum. In this case, the fringes of the interferogram are narrowly localized into a path length difference region so the variation of the path length difference can be determined without the  $2\pi$  ambiguity by locating the fringe peak or the envelope peak of the interferogram. This type of interferometry is known as white-light or low-coherence interferometry. Opsens' founders are known to have pioneered the use of white-light interferometry for fiber optic sensing and to have brought this type of sensing technology to the industrial sensors marketplace. They are now proud to introduce the latest advance in that domain with their improved fiber optic sensing technology: the *White-Light Polarization Interferometry* technology (covered by patents in multiple countries).

## 2. Fiber optic Transducer

Opsens fiber optic transducers are of interferometric type except those based on the SCBG technology (see SCBG section for more information on this type of transducers). Depending of the measurand of interest (pressure, temperature, etc), Opsens has selected the best interferometer type and the best configuration for the design of its fiber optic transducers. All Opsens transducers are made with industry-standard components such as multimode optical fibers and connectors providing to the customer a significant acquisition cost advantage.

Figure 1 shows the schematic design for each transducer of the specified measurand. For all of these types of transducers, a change in the magnitude of the applied measurand results into a change of the path length difference  $\delta_s$  of the transducer sensing interferometer. Therefore the path length difference can be thought as the output of the transducer although we know that the physical or real output is the light signal that carries the information about  $\delta_s$ . The relationship between the applied measurand  $M$  and the output ( $\delta_s$ ) of the transducers, referred to as the transducer

signal output, can be represented by the following equation

$$\delta_s = S \cdot M + \delta_o \quad (1)$$

where  $S$  is the sensitivity of the transducer, that is the ratio of change in transducer output to a change in the value of the measurand, and  $\delta_o$  is the zero-measurand output.

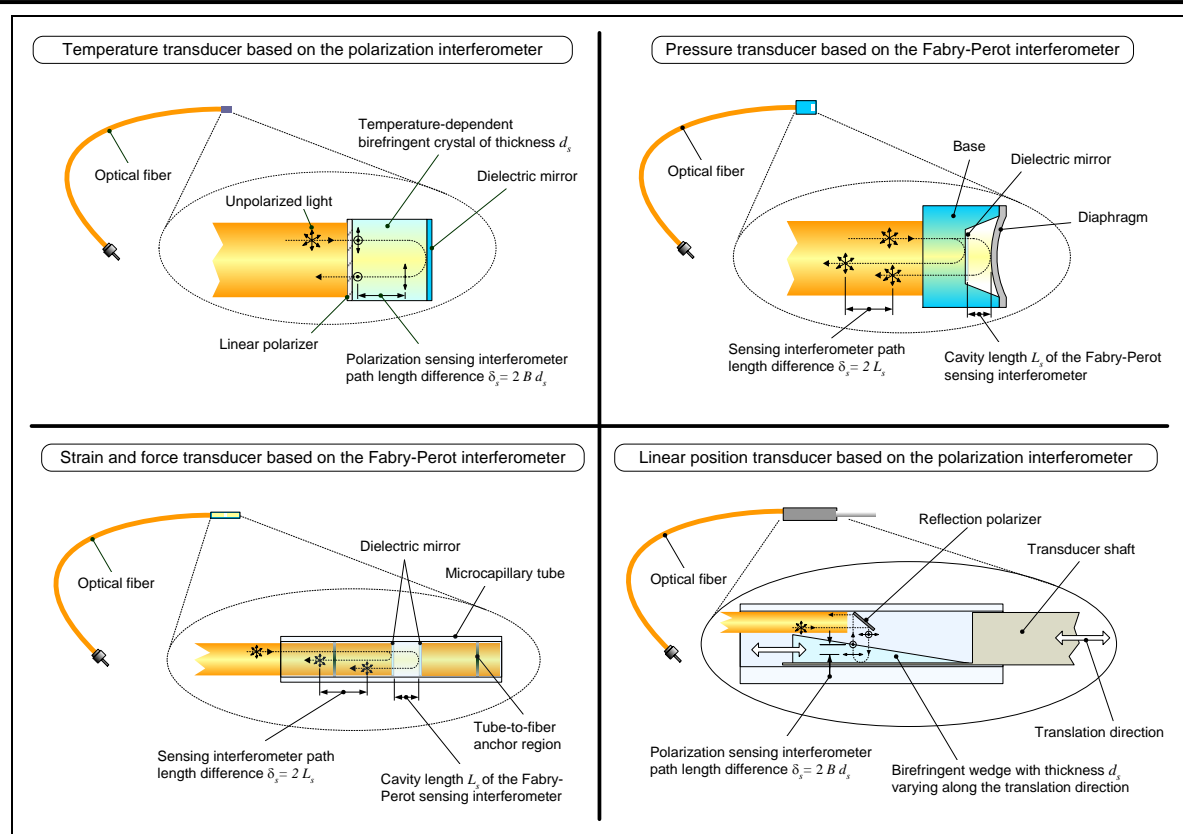

Figure 1: Various WLPI-based fiber optic transducers

### 2.1.1. Fiber optic temperature transducer

A schematic description of Opsens fiber optic temperature transducer is illustrated at the top left of Figure 1. The temperature transducer is based on the polarization interferometer made of a birefringent crystal (covered by patents in multiple countries). The temperature-dependent birefringence of specially selected crystal is used for the transduction mechanism. A linear polarizer is placed at the input face of the birefringent crystal and its end face is coated with a dielectric mirror. These components form a two-beam polarization interferometer having a path length difference

$$\delta_s = 2 \cdot B \cdot d_s \quad (2)$$

where  $B$  and  $d_s$  are respectively the temperature-dependent birefringence and the thickness of the crystal. The transducer signal output as a function of the temperature  $T$  is given by the following equation

$$\begin{aligned} \delta_s(T) &= S \cdot T + \delta_o = 2 \cdot \frac{\partial}{\partial T} (B \cdot d_s) \cdot T + \delta_o \\ &\cong 2 \cdot \frac{\partial B}{\partial T} \cdot d_s \cdot T + \delta_o \end{aligned} \quad (3)$$

Equation (3) shows that the sensitivity of the fiber optic transducer depends mainly on the temperature coefficient of birefringence ( $\partial B / \partial T$ ) of the crystal used. This is an

important feature because different crystals can be used for temperature sensing and this selection of crystals offers a range of sensitivity that varies by two orders of magnitude! This means that fiber optic temperature transducers can be designed with various operating temperature range, resolution and accuracy. For example, if large temperature operating temperature range is not required, then temperature transducer with very high resolution can be made using crystal with a large temperature coefficient of birefringence. Indeed, Opsens uses a specially selected crystal in its medical fiber optic temperature providing an outstanding resolution and accuracy.

Other advantages of this temperature transducer design are the small size of its polarization interferometer and the fact that it has no moving part. This last point significantly differentiates Opsens' temperature transducers from other commercially available fiber optic temperature transducers based on the Fabry-Perot interferometer design. It is worth noting on this point that the Fabry-Perot interferometer design used for temperature measurement is based on the thermal dilatation of one or both of the glass optical fibers of the interferometer. Consequently, the temperature-induced change of the interferometer path length difference relies on the mechanical properties of an amorphous material. It is well known that amorphous glasses can suffer from hysteresis in thermal dilatation and from thermal-creep as well. These problems can significantly affect the short and long term accuracy of the temperature transducer. On the other hand, the polarization design used in Opsens temperature transducers relies on the optical properties, namely the birefringence, of a monocrystalline material, which property is known to be very reproducible and stable over time.

### 2.1.2. Other transducers

The principle of operation of other Opsens transducers, such as the fiber optic pressure, strain or displacement transducer is illustrated

in Figure 1. The output, which is the path length difference  $\delta_s$  of the transducer sensing interferometer, remains the same for each type of transducers. The relationship between the specific measurand and the transducer output is given by an expression similar to Equation (1). For more information, please consult our specific product datasheets available for each of these transducers.

### 3. Fiber optic Signal Conditioner

The WLPI technology is found at the heart of Opsens' signal conditioners. This technology provides a mean for making absolute measurements of the path length difference of any type of interferometric fiber optic transducers, whose difference varies according to the measurand of interest. For example, the WLPI signal conditioner is able to measure the path length difference of temperature transducers based on the polarization interferometer, position transducers based on the Michelson interferometer or on the polarization interferometer, pressure, temperature or strain transducers based on the Fabry-Perot interferometer, etc, and this, with an accuracy and reliability never reached before.

A schematic of the WLPI technology is illustrated in Figure 2. The interferometric fiber optic transducer is schematically represented as a two-beam sensing interferometer (beam (1) and beam (2)). Broadband light is launched from the signal conditioner into the fiber optic transducer. The light beam reaches the sensing interferometer where it is divided into two beams. The two split-beams travel through different paths (path (1) and (2)). The length difference between path (1) and (2), namely the path length difference, varies as a function of the measurand of interest.

The two split beams are recombined and reflected back to the signal conditioner. At this point, it is important to note that the light signal received at the signal conditioner from the interferometric transducer does not show any periodic modulation due to interference effects. This is because the coherence length of the

source used is shorter than the path length difference of the transducer interferometer. However, as we will show next, the light signal carries accurate and unambiguous information on the path length difference of the sensing interferometer that is related to the measurand.

Light received from the transducer is fed into the readout interferometer of the signal conditioner (Figure 2 shows a multi-channel signal conditioner). Opsens readout interferometer (patent pending) is a static polarization interferometer, based on the two-beam interferometer configuration, having a spatially distributed path length difference variation along a direction (x direction on Figure 2). It comprises a solid wedge made of a birefringent crystal specially selected for that purpose. Light beam going through the readout interferometer is first spread over the width of the birefringent wedge. The light is

decomposed into two orthogonal linear polarization components (indicated by a double arrow and by a dotted circle on Figure 2 using a linear polarizer and then enters into the wedge. Because of the anisotropic properties of the wedge crystal, the two polarization components move at different speed into the wedge so at the output, the two components are shifted away from each other. The path length difference  $\delta_r$  between the two orthogonal polarization components at the wedge output is given by:

$$\delta_r(x) = B \cdot d(x) \tag{4}$$

where  $B$  is the birefringence and  $d(x)$  is the thickness of the wedge at position  $x$ . Another linear polarizer is placed behind the wedge and recombines the two orthogonal polarization components so they can interfere.

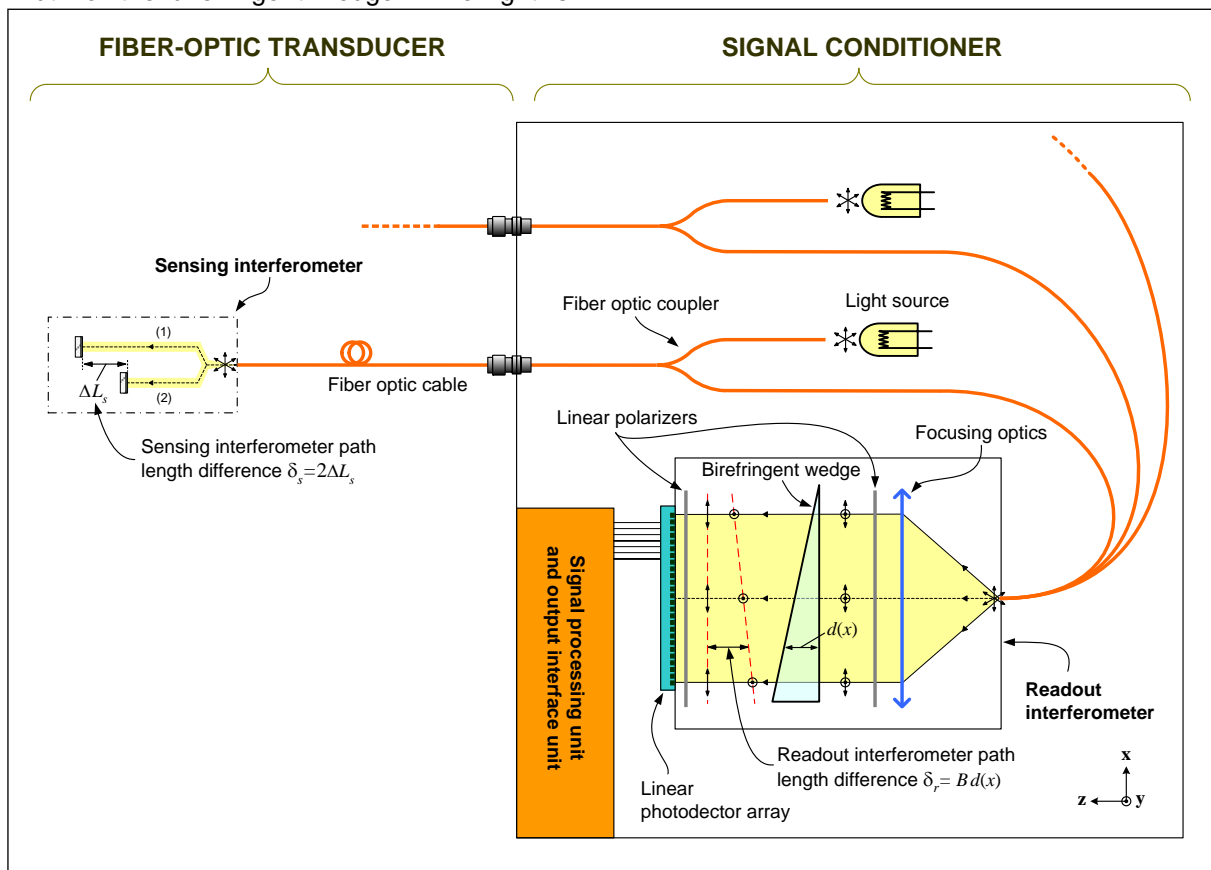

Figure 2: Schematic of the WLPI technology

The spatial distribution of the light intensity at the output of the readout interferometer is measured using a linear photodetector array. Optical coherence theory shows that the light signal recorded by the linear photodetector array, referred to as an interferogram, can be represented by a modulated sinusoid that has an envelope with a maximum at  $\delta_r = \delta_s$  and falls off monotonically with  $\delta_r$ .

Figure 3A and 3B show two typical interferogram signals measured by the signal conditioner for two measurand values  $M_1$  and  $M_2$ . Each interferogram depicts the light intensity distribution  $I_r(\delta_r)$  versus the path length difference  $\delta_r$  of the readout interferometer. The solid curve represents the sinusoidal fringes while the dotted curve represents the envelope of the fringes. The position of either the fringe peak or that of the envelope peak is located where the path length difference of the readout interferometer is equal to the one of the sensing interferometer, i.e. when  $\delta_r = \delta_s$ . Therefore, the measure of  $\delta_r$  leads to that of  $\delta_s$ , i.e. using a calibrated readout interferometer, the measure of the position of the fringe peak or that of the envelope peak of the interferogram signal provides all the necessary information for accurately determining the value of  $\delta_s$  and consequently that of the measurand  $M$ .

We can now clearly see all the advantages of the WLPI technology: the value of the path length difference does not depend on the parameters of the classical interferometry, namely the phase and amplitude of the signal, but only on the fringe or the envelope peak position.

This technique is therefore very robust against spurious effects that may affect the measurement of the interferogram light signal. Clearly speaking, a change of the light intensity due, for example, to connection losses or light source fluctuations, changes the intensity level of the interferogram but does not affect the position of the fringe peak or that of the envelope peak; and because the measure of  $\delta_r$

is absolute with no  $2\pi$  ambiguities, there is no loss of reference when turning off the signal conditioner.

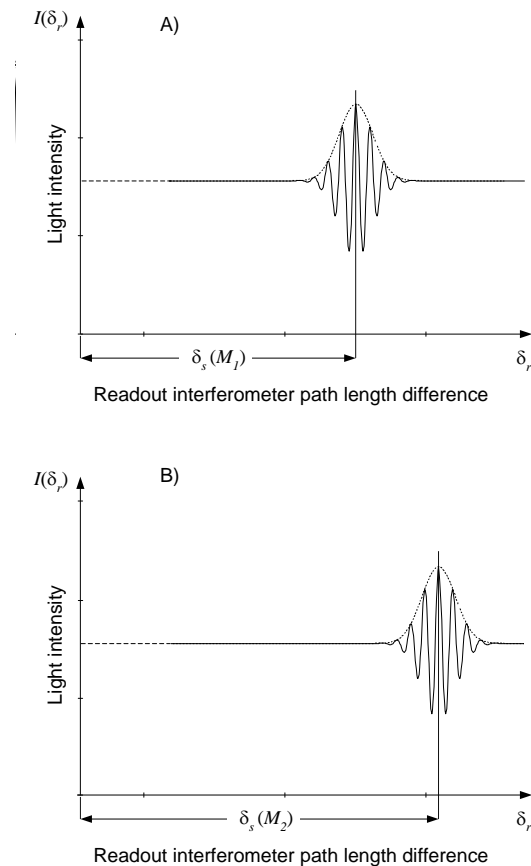

Figure 3

Additionally, unlike the Fizeau interferometer (a multiple-beam interferometer) found in some commercially available fiber optic signal conditioners, the readout interferometer used in the WLPI technology is a real two-beam interferometer. Using such type of interferometers provides an interferogram signal with a visibility two times larger than that of a multiple-beam interferometer like the Fizeau interferometer. The end result is a higher precision and resolution in the measurements. And with its unique design which contains no moving parts and no mirrors in the interferometer arms, the WLPI readout interferometer comes with superior mechanical

stability over long period of time and consequently with minimum needs for recalibration.

Once the signal conditioner has processed the interferogram signal to extract the value of  $\delta_r$  and consequently, of  $\delta_s$ , it uses the following equation to output the value of the measurand  $M$

$$M = \frac{(\delta_s - \delta_o)}{S} \quad (5)$$

If the transducer output signal is linear in  $M$ , that is its sensitivity  $S$  does not depends of  $M$ , equation (5) is easily solved knowing the constant parameters  $S$  and  $\delta_o$ . These two parameters constitute the transducers calibration parameters provided by Opsens. In the non-linear case, there are generally more than two transducer calibration parameters provided in order to accurately represent the non linear response of the transducer. In any case, Opsens' signal conditioner firmware is made to handle both linear response and non-linear response of the transducer.

Prior to use the transducer, the calibration parameters have to be saved into the non-volatile memory of the signal conditioner. To make things easy, Opsens identifies each transducer with a single calibration number in which all the calibration parameters are encoded. The user enters the calibration number once in the non-volatile memory of the signal conditioner by selecting the appropriate function on the conditioner display menu or by using the computer communication software delivered with the conditioner.

#### 4. Conclusion

The WLPI technology offers a great degree of flexibility in the design of various types of fiber optic transducers. Numerous measurement and sensing applications can therefore benefits from this advantageous feature and combined with its outstanding performances, the WLPI technology is aimed to respond to the most demanding ones!